

RS 232 communication

Configuration

Nordex – CC

RS 232 communication

Table of contents

1. Introduction.....	3
2. Nordex CC Controller.....	4
3. Mitsubishi A1SJ71QC24 communication module	5
4. Mitsubishi A1SJ71UC24-R4-S2 communication module.....	6
5. ICP CON RS422 to RS232 converter.....	7
6. Cables	8
6.1. Cable layout for F2403	8
6.2. Cable layout for F2816 - COM 1.....	9
6.3. Cable layout for F2816 - COM 2.....	9
7. Four Faith – Signal monitoring.....	10
7.1. F2403 Signal monitoring	10
7.2. F2816 Signal monitoring	11

1. Introduction

This document shows how to enable RS232 communication on a turbine with Nordex CC controller.

The document includes:

- How to change parameter and which settings needs to be changed.
- Cable connections.

2. Nordex CC Controller

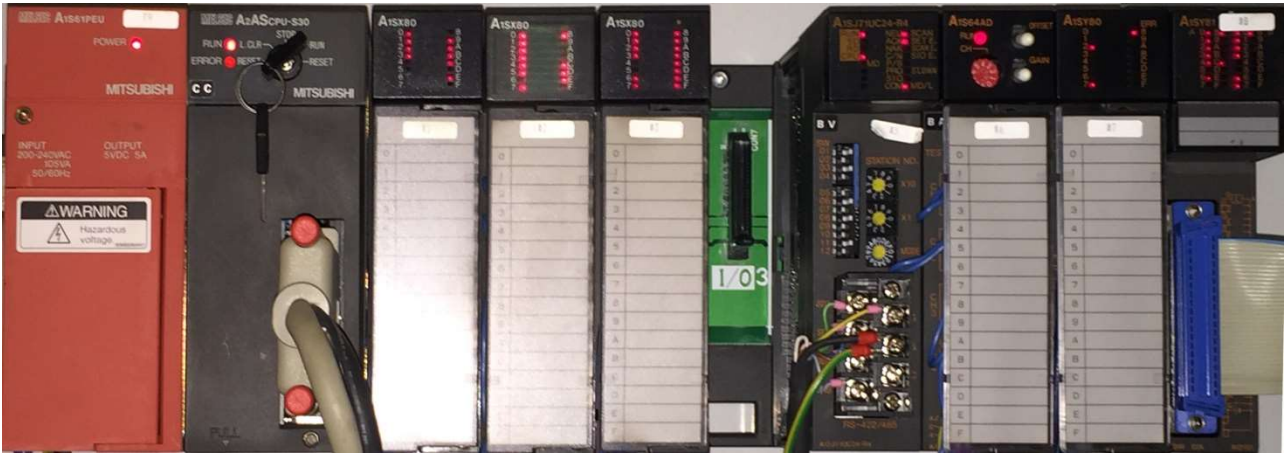

The Nordex CC controller uses a Mitsubishi A1SJ71UC24-R4-S2 or A1SJ71QC24 module with RS422 interface.

This is typically setup for:

Communication: 9600 7E1.
Communication id is 1

But it can be configured on the DIP switches and dials on the communication module. (See the following chapters).

3. Mitsubishi A1SJ71QC24 communication module

The Station number is the turbines communication id number. It is defined by the two station number switches where the com id = $X10 * 10 + X1$

Eg. Switch X10 is set to 2 and X1 is set to 1. This gives the com id number 21.

It is normally set to $X10 = 0$ and $X1 = 1$

Mode must be set to 8.

Dip switch 1 to 8 must be set to:

DIP 1	ON	Linked opr.
DIP 2	OFF	7 Data bits
DIP 3	ON	Parity
DIP 4	ON	Even parity
DIP 5	OFF	1 stop bit
DIP 6	ON	CRC on
DIP 7	ON	Write enabled
DIP 8	ON	Setting change Enabled

If you have the communication module with 2 channels is CH1 the RS422 port on the front and CH2 is the RS232 port in the bottom of the module.

Please ensure that you set the DIP switches on the right channel depending on the connection type.

· A1SJ71QC24

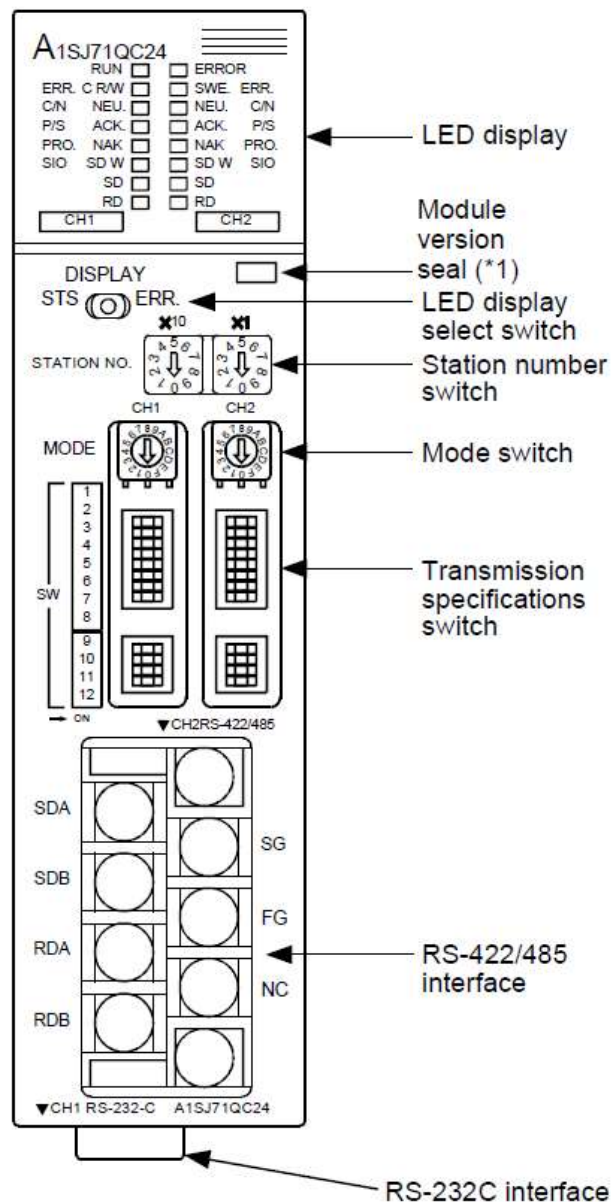

DIP 9 to 12 is used to set the communication speed.

		Transmission speed (unit: bps)											
		300	600	1200	2400	4800	9600	19200	38400	14400	28800	57600	115200
Switch	SW09	OFF	ON	OFF	ON	OFF	ON	OFF	ON	OFF	ON	OFF	ON
	SW10	OFF	OFF	ON	ON	OFF	OFF	ON	ON	OFF	OFF	ON	ON
	SW11	OFF	OFF	OFF	OFF	ON	ON	ON	ON	OFF	OFF	OFF	OFF
	SW12	OFF	OFF	OFF	OFF	OFF	OFF	OFF	OFF	OFF	ON	ON	ON

4. Mitsubishi A1SJ71UC24-R4-S2 communication module

The Station number is the turbines communication id number.

It is defined by the two station number switches where the
 $com\ id = X10 * 10 + X1$

Eg. Switch X10 is set to 2 and X1 is set to 1.
 This gives the com id number 21.
 It is normally set to X10 = 0 and X1 = 1

Mode must be set to 8.

Dip switch 1-4 and 8-12 must be set to:

DIP 1	OFF	NC
DIP 2	ON	Computer link
DIP 3	OFF	A1ADP-SP not used
DIP 4	ON	Write during RUN
DIP 8	OFF	7 bits
DIP 9	ON	Parity on
DIP 10	ON	Even parity
DIP 11	OFF	1 stop bit
DIP 12	ON	NC

DIP 5 to 7 is used to set the communication speed.

Setting switch	Transmission speed (unit: bps)							Setting prohibited
	300	600	1200	2400	4800	9600	19200	
SW05	OFF	ON	OFF	ON	OFF	ON	OFF	ON
SW06	OFF	OFF	ON	ON	OFF	OFF	ON	ON
SW07	OFF	OFF	OFF	OFF	ON	ON	ON	ON

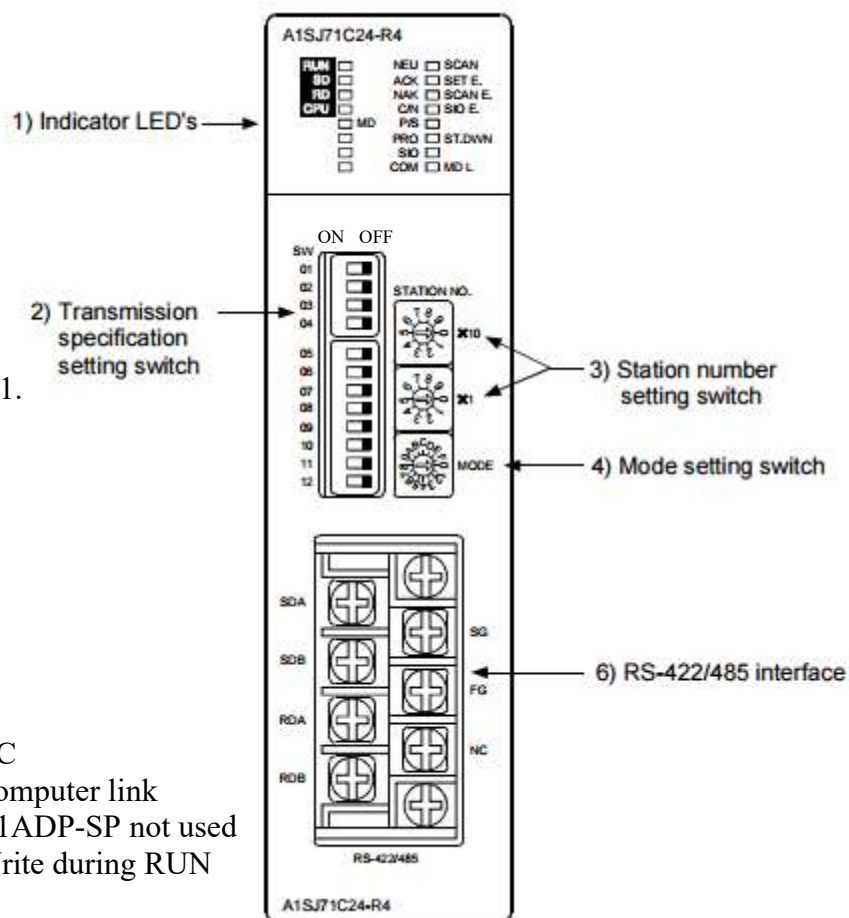

5. ICP CON RS422 to RS232 converter



Cable connections:

ICP CON	Cable color	Mitsubishi module
Data +		
Data -		
NC		
TX+	Yellow	RDA
TX-	Green	RDB
RX+	Brown	SDA
RX-	White	SDB
NC		
V+	Power supply +12V	
GND	Power supply GND	

6. Cables

6.1. Cable layout for F2403

Four-Faith		Nordex CC
<u>DB9 Female</u>		<u>DB9 Male</u>

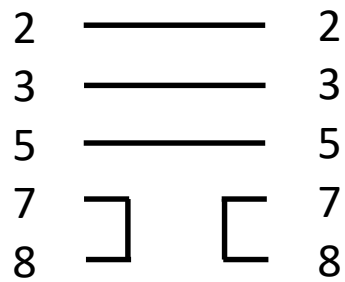

6.2. Cable layout for F2816 - COM 1

Four-Faith 2816		Nordex CC	
<u>Terminal</u>		<u>DB9 Male</u>	
3	—————	2	Green
4	—————	3	White
5	—————	5	Brown
1 PWR		7	
2 GND	┌	8	

6.3. Cable layout for F2816 - COM 2

Four-Faith 2816		Nordex CC	
<u>Terminal</u>		<u>DB9 Male</u>	
6	—————	2	Green
7	—————	3	White
5	—————	5	Brown
1 PWR		7	
2 GND	┌	8	

The Power (PWR) must be between +5V to +36V DC (Standard power supply is 12V DC)

An easy way to check if the wires on pin 3 and 4 (COM1) or pin 6 and 7 (COM2) is mounted correct is to measure the DC voltage on both pins in reference to GND (pin 5). If the Rx and Tx wires are mounted correct, should it be possible to measure a voltage on both pins (Above 3 volts). If there is only voltage on one pin is the wires wrong and they must be flipped.

7. Four Faith – Signal monitoring

7.1. F2403 Signal monitoring

The Four Faith F2403 GPRS modem can be used to monitor the signal strength during installation.

This can be done on units bought after October 2014 and with firmware versions after this date.

The Signal mode is activated using a special DB9 adaptor that is inserted into the RS232 port on the Four Faith modem. When the adaptor is inserted will the online LED on the modem not display the online status anymore but instead will the signal strength be display. The signal level is illustrated by a number of blinks that is repeated every 3 seconds.

There are 5 different blink levels.

Level	Signal strength (dBm)	Quality
1	-113 -> -103	Bad
2	-101 -> -95	Marginal
3	-93 -> -85	OK
4	-83 -> -75	Good
5	-73 or higher	Excellent



The GPRS modem will not attempt to connect unless the signal strength is 2 or above but the signal should be no less than 3 or more before a stable connection can be expected.

Be aware that when the Signal tester adaptor is inserted will the modem NOT attempt to go online. The modem will return to normal operation when the adaptor is removed.

7.2. F2816 Signal monitoring

The Four Faith F2816 GPRS modem can be used to monitor the signal strength during installation.

The Signal mode is activated by pressing the signal tester button on the “Multiport interface” unit. The button has to be kept pressed during the signal testing.

If the kit is not equipped with the signal tester button can the signal mode be activated by connecting pin 11 (IO2) to the ground pin 2 or 5.

When the connection is established will the online LED on the modem not display the online status anymore but instead will the signal strength be display. The signal level is illustrated by a number of blinks that is repeated every 3 seconds.

There are 5 different blink levels.

Level	Signal strength (dBm)	Quality
1	-113 -> -103	Bad
2	-101 -> -95	Marginal
3	-93 -> -85	OK
4	-83 -> -75	Good
5	-73 or higher	Excellent



The GPRS modem will not attempt to connect unless the signal strength is 2 or above but the signal should be no less than 3 or more before a stable connection can be expected.

Be aware that when the Signal tester is active will the modem NOT show the online signal anymore. The modem will return to normal operation when the adaptor is removed.